

# Butter

FAYE TOOGOOD



**Tacchini**



Tacchini has been creating timeless furniture and accessories since 1967. Renowned for its refined design philosophy, the brand combines respect for tradition with openness to innovation. Its collections, distinguished by classic design taste and impeccable quality, express a language in delicate balance between formal rigor and poetry, understatement and boldness, sophistication and simplicity. But for Tacchini, style is above all a state of mind. It manifests in respect for people, materials, craftsmanship, the environment, and history, in continuity with the teachings of the great masters.

Founded in Seveso, in the production district of Brianza, the company established half a century ago by Antonio Tacchini is today a reference point for Made in Italy. Under the guidance of his daughter, Giusi Tacchini, CEO and Art Director, it continues to interpret its original values through collaborations with international designers and local artisans: an extraordinary synergy that enhances the unique ability of Brianza to transform ideas into products of excellence - the icons of tomorrow. The objects created by Tacchini are unmistakable, but their understated elegance never steals the spotlight. They are discreet and reliable companions, ready to adapt harmoniously to the environments in which they are placed and to the lives of those who choose them. With their unique stories, they become part of someone else's history.

## Between past and present

**“At Tacchini, great design classics and contemporary pieces coexist in a constant dialogue. These two souls merge and respect each other, creating spaces that embody a classic and recognizable style, perfectly balancing between modernity and timelessness.”**

Giusi Tacchini, CEO & Creative Director



# Index

Butter Sofa	08
Faye Toogood	10
Composition BT16/BT14   Interior 01	12
Composition BT21   Interior 01	20
Composition BT17   Interior 01	30
Composition BT5   Interior 01	42
Composition BT7   Interior 01	56
Composition BT10   Interior 01	66
Composition 01L   Set 01	76
Composition 02M   Set 02	78
Composition 03S   Set 03	80
Composition 04L   Set 04	82
Composition 05M   Set 05	84
Composition 06S   Set 06	86
Technical Data	89
Suggested Compositions	90
Butter Sofa Modules	92
Butter Collection Modules	97

## Butter Sofa

**“I wanted to create a chair as comforting, and as tactile as soft butter. Modelling with slippery fingers, the modular Butter Sofa appeared. Every-day life is a thing of beauty. Sometimes you need go no further than the breakfast table to find meaning. Slice a loaf of bread. Look at it from a new perspective.”**

Faye Toogood

Butter Sofa is a soft and sculptural modular sofa, shaped from a lump of butter. It is part of the Bread and Butter collection created in collaboration with Faye Toogood. In keeping with the experimental spirit and unconventional creative processes of the Toogood studio, the Butter Sofa takes shape from a lump of Cornish butter moulded by slippery fingers. Generously padded — soft, tactile, and comforting, just like butter — the sofa rests on large volumes reminiscent of building blocks, modular and easily reconfigurable.



## Faye Toogood



Faye Toogood is one of the most original voices in contemporary design. Growing up in the English countryside, she began her career as a stylist at The World of Interiors before founding an interdisciplinary studio in London, where she collaborates with architects, sculptors, and illustrators, including her sister Erica.

She has always rejected being confined to a single discipline and now works in interior design, home objects, fine arts, and fashion, sharing with her sister a passion for experimentation and craftsmanship in telling stories that blend Faye's interest in materials with Erica's tailoring expertise.

Faye Toogood's approach is based on a deep love for materials, very tactile and unpretentious. Guided by an infallible instinct, she mixes ideas and experiments alongside her collaborators, free and without labels, much like herself. Much of her work is dedicated to creating something beautiful from simple and everyday materials, easily found everywhere. The landscape of her childhood also continues to permeate her projects, whether it's a bronze handle cast from an abandoned skeleton, a fashion collection inspired by hay bales, or the interiors of a house painted with the palette of an English sky.





Butter Sofa by Faye Toogood, 2026, upholstery Umber 09. Artona Armchair by Tobia Scarpa, 2026, finish T135 Canaletto Walnut, upholstery Velisse 01. Core Bar Cabinet by Tacchini Design Studio, 2026, finish T238 Glossy Ebony. Dana Lamp by Jean-Pierre Garrault & Henri Delord, 2024.



Butter Sofa by Faye Toogood, 2026, upholstery Umber 09. Astral Cabinet by Faye Toogood, 2024, finish T188 Glossy Green. Colonna Side Tables by Roberto Sironi, 2026, top T211 Brushed Sicilian Breccia Marble, base T149 Mirror.

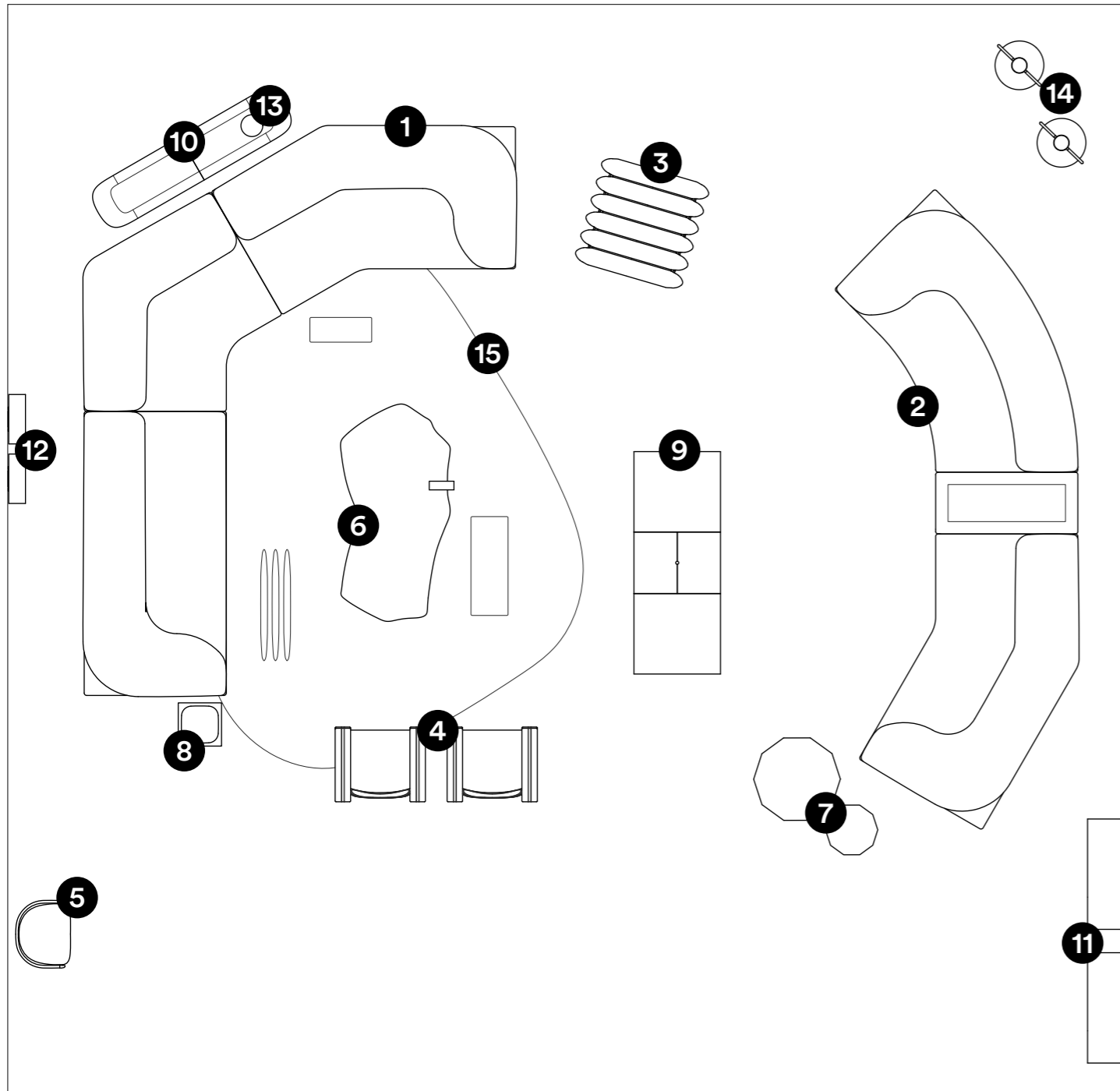

- |  |  |
|--|--|
| <p>1 Butter Sofa Composition BT16<br/><b>Faye Toogood</b><br/>Upholstery Efeu 08</p> <p>2 Butter Sofa Composition BT14<br/><b>Faye Toogood</b><br/>Upholstery Efeu 08</p> <p>3 Additional System Armchair<br/><b>Joe Colombo</b><br/>Upholstery Zareen 05</p> <p>4 Artona Armchair<br/><b>Tobia Scarpa</b><br/>Finish T135 Canaletto Walnut, upholstery Velisse 01</p> <p>5 Pigreco Chair<br/><b>Tobia Scarpa</b><br/>Finish T225 Glossy Lacquered Light Blue, upholstery Tiare 02</p> <p>6 PietraForma Side Table<br/><b>Roberto Sironi</b><br/>Top T236 Orobico Grey Matt Marble, legs T135 Canaletto Walnut</p> <p>7 Colonna Side Tables<br/><b>Roberto Sironi</b><br/>Top T211 Brushed Sicilian Breccia Marble, base T149 Mirror</p> <p>8 Bread Side Tables<br/><b>Faye Toogood</b><br/>Structure T134 Walnut Stained, insert Maple wood</p> | <p>9 Core Bar Cabinet<br/><b>Tacchini Design Studio</b><br/>External finish T238 Glossy Ebony</p> <p>10 Butter Storage Cabinet<br/><b>Faye Toogood</b><br/>Finish T223 Glossy Lacquered Beige</p> <p>11 Astral Storage Cabinet<br/><b>Faye Toogood</b><br/>Finish T188 Glossy Green</p> <p>12 Doric Lamp<br/><b>Umberto Bellardi Ricci</b></p> <p>13 Miss Pack Lamp<br/><b>Alvino Bagni</b><br/>Finish T100 Green</p> <p>14 Dana Lamp<br/><b>Jean-Pierre Garrault &amp; Henri Delord</b></p> <p>15 Onigiri Rug<br/><b>Studiopepe</b><br/>Color Brown</p> |
|--|--|

Composition BT16/BT14

Butter Sofa  
Composition BT16

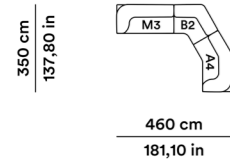

Artona Armchair  
OARTPL01

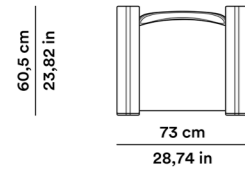

Colonna Side Table H48 cm  
OCLNTB01



Core Bar Cabinet  
OCREMB180

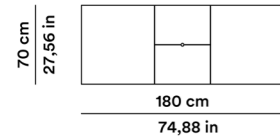

Doric Lamp  
ODRC01

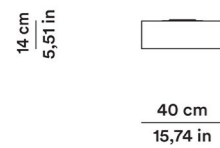

Interior 01

Butter Sofa  
Composition BT14

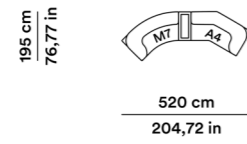

Pigreco Chair  
OPGRSD

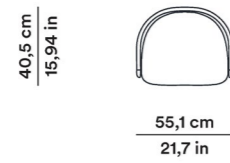

Colonna Side Table H26 cm  
OCLNTB02

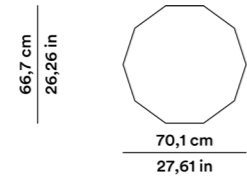

Butter Storage Cabinet  
OBTTLB01LL

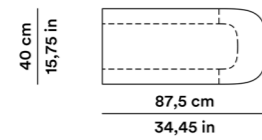

Miss Pack Lamp  
OMSP01

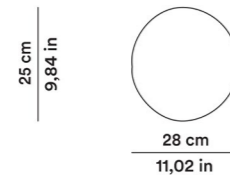

Additional System Armchair  
OADSPL090

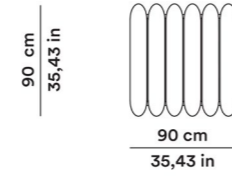

PietraForma Side Table  
OPTFTB17501

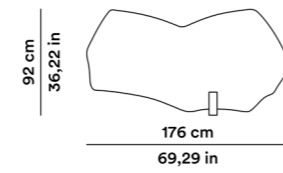

Bread Side Tables  
OBRDTB02

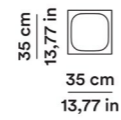

Astral Cabinet  
OATLLB150

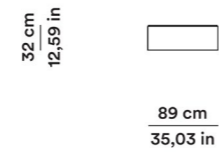

Dana Lamp  
ODNA01

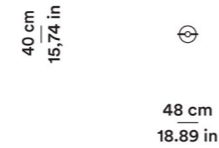

Composition BT16/BT14

Onigiri Rug  
OONGTP437X315

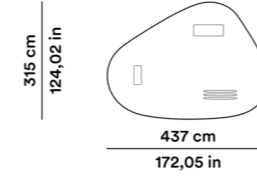

Interior 01

Fabrics & Leathers

Finishes



EFEU 08



ZAREEN 05

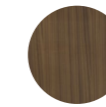

T135 CANALETTO  
WALNUT



T236 OROBICO GREY  
MATT MARBLE



T211 SICILIAN  
BRECCIA MARBLE



T149 MIRROR



VELISSE 01



TIARE 02



T134 WALNUT  
STAINED



MAPLE WOOD

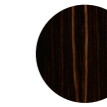

T238 GLOSSY  
EBONY



T223 GLOSSY  
LACQUERED BEIGE



T225 GLOSSY  
LACQUERED  
LIGHT BLUE



T188 GLOSSY  
GREEN



T100 GREEN



ONIGIRI  
BROWN





Butter Sofa by Faye Toogood, 2026, upholstery Efeu 07. Giulia Armchair by Gianfranco Frattini, (1957) 2016, structure T202 Glossy Lacquered Chocolate, upholstery Sahara 01. Serie 500/3 Storage Cabinet by Gianfranco Frattini, 2024, finish T220 Matt Lacquered Grey. Tact & Trace Mirrors by Objects of Common Interest, 2025. Pablo Vase by Studiopepe, 2020.



Butter Sofa by Faye Toogood, 2026, upholstery Efeu 07. Colonna Side Table by Roberto Sironi, 2026, top T237 Light Onix Matt Marble, base T149 Mirror. Core Bar Cabinet by Tacchini Design Studio, 2026, external finish T239 Glossy Rosewood. Jacob Rug by Salem van der Swaagh, 2024, White.

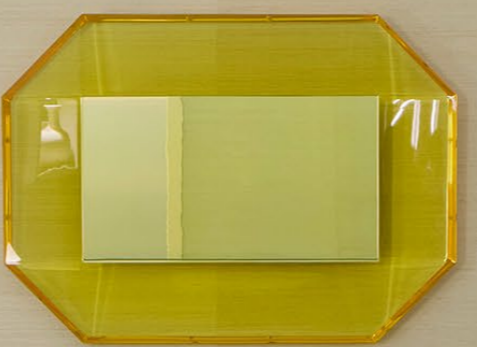

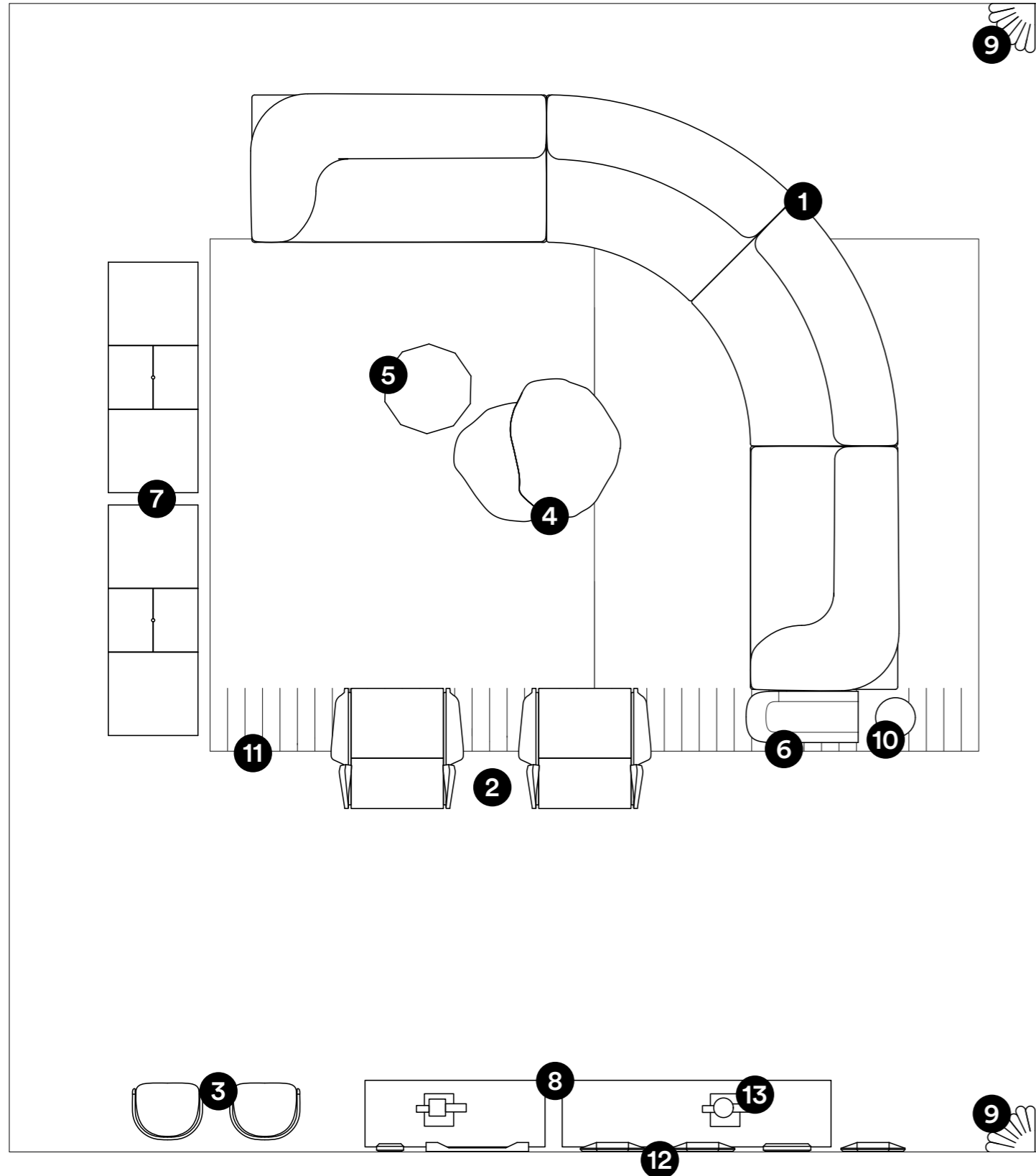

- |  |  |
|--|--|
| <p>1 Butter Sofa Composition BT21<br/><b>Faye Toogood</b><br/>Upholstery Efeu 07</p> <p>2 Giulia Armchair<br/><b>Gianfranco Frattini</b><br/>Finish T202 Glossy Lacquered Chocolate, upholstery Sahara 01</p> <p>3 Pigreco Chair<br/><b>Tobia Scarpa</b><br/>Finishes T202 Glossy Lacquered Chocolate, T223 Glossy Lacquered Beige, upholstery Tar 04 + Tiare 03</p> <p>4 Brut Side Table<br/><b>Roberto Sironi</b><br/>Top Aluminum, legs Grey Cement</p> <p>5 Colonna Side Table<br/><b>Roberto Sironi</b><br/>Top T237 Light Onix Matt Marble</p> <p>6 Butter Storage Cabinet<br/><b>Faye Toogood</b><br/>Finish T173 Glossy Lacquered Ivory</p> <p>7 Core Bar Cabinet<br/><b>Tacchini Design Studio</b><br/>External finish T239 Glossy Rosewood</p> | <p>8 Serie 500 Storage Cabinet<br/><b>Gianfranco Frattini</b><br/>Top T220 Matt Lacquered Grey</p> <p>9 Vertical Nest Wall Lamp<br/><b>Brian Thoreen</b></p> <p>10 1809 Lamp<br/><b>Tacchini Design Studio</b></p> <p>11 Jacob Rug<br/><b>Salem van der Swaagh</b><br/>Color White</p> <p>12 Tact &amp; Trace Mirrors<br/><b>Objects of Common Interest</b></p> <p>13 Pablo &amp; Dora Vases<br/><b>Studiopepe</b></p> |
|--|--|

Composition BT21

Butter Sofa  
Composition BT21



Interior 01

Giulia Armchair  
OGLAPL085

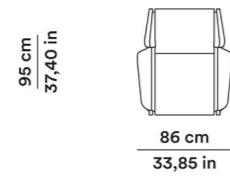

Composition BT21

Trace 01  
OTRC01

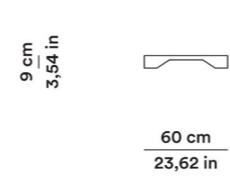

Interior 01

Pablo Vase  
OPBL01

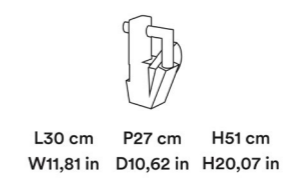

Dora Vase  
ODRA01

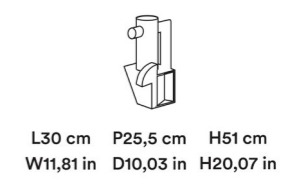

Brut Side Table  
OBRTTB130

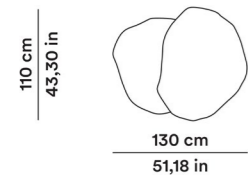

Colonna Side Table  
OCLNTB02

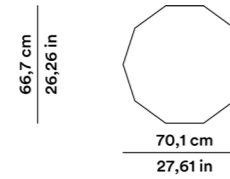

Butter Storage Cabinet  
OBTTLB01LL

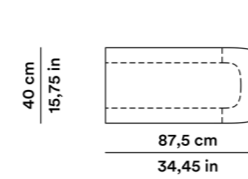

Core Bar Cabinet  
OCREMB180

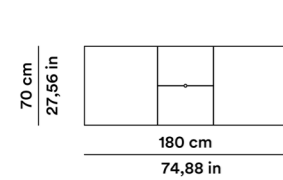

Serie 500/3 Storage Cabinet  
0503CR210

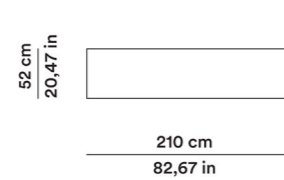

Serie 500/4 Storage Cabinet  
0504MD140

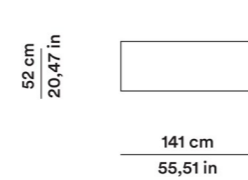

Vertical Nest Floor Lamp  
OVRN01

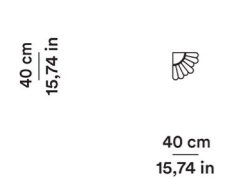

1809 Lamp H110 cm  
01809A



Jacob Rug  
OJCBTP300X400

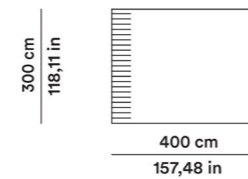

Tact 01  
OTCT01

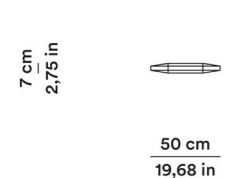

Tact 02  
OTCT02

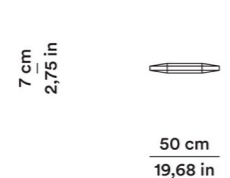

Tact 03  
OTCT03

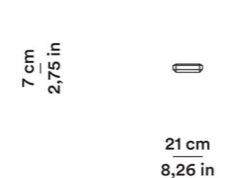

Fabrics & Leathers

Finishes



EFEU 07



SAHARA 01



T202 GLOSSY LACQUERED CHOCOLATE



T223 GLOSSY LACQUERED BEIGE



ALUMINUM



GREY CEMENT



TAR 04



TIARE 03



T237 LIGHT ONIX MATT MARBLE



T173 GLOSSY LACQUERED IVORY

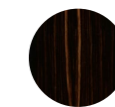

T239 GLOSSY ROSEWOOD



T220 MATT LACQUERED GREY



JACOB  
WHITE





Butter Sofa by Faye Toogood, 2026,  
upholstery Efeu 01.

Butter Storage Cabinet by Faye Toogood, 2026,  
finish T173 Glossy Lacquered Ivory.





Butter Sofa by Faye Toogood, 2026, upholstery Efeu 01.



Butter Low Table by Faye Toogood, 2026, top semi-gloss Classic Roman Travertine marble, upholstery Efeu 01. Onigiri Rug by Studioepepe, 2026, White.

Composition BT17

Interior 01

- 1 **Butter Sofa Composition BT17**  
**Faye Toogood**  
Upholstery Efeu 01
- 2 **Artona Armchair**  
**Tobia Scarpa**  
Structure T134 Walnut Stained, upholstery Velisse 01
- 3 **Butter Low Table**  
**Faye Toogood**  
Top semi-gloss Classic Roman Travertine marble, upholstery Efeu 01

- 4 **Butter Storage Cabinet**  
**Faye Toogood**  
Finish T173 Glossy Lacquered Ivory
- 5 **Onigiri Rug**  
**Studiopepe**  
White

Composition BT17

Interior 01

**Butter Sofa**  
**Composition BT17**

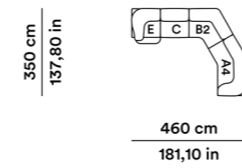

**Artona Armchair**  
**OARTPL01**

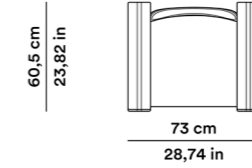

**Butter Low Table**  
**P2 - OBTTTB01**

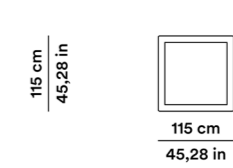

**Butter Storage Cabinet**  
**OBTTLB01LL**

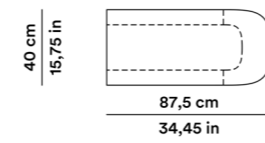

**Onigiri Rug**  
**OONGTP375X246**

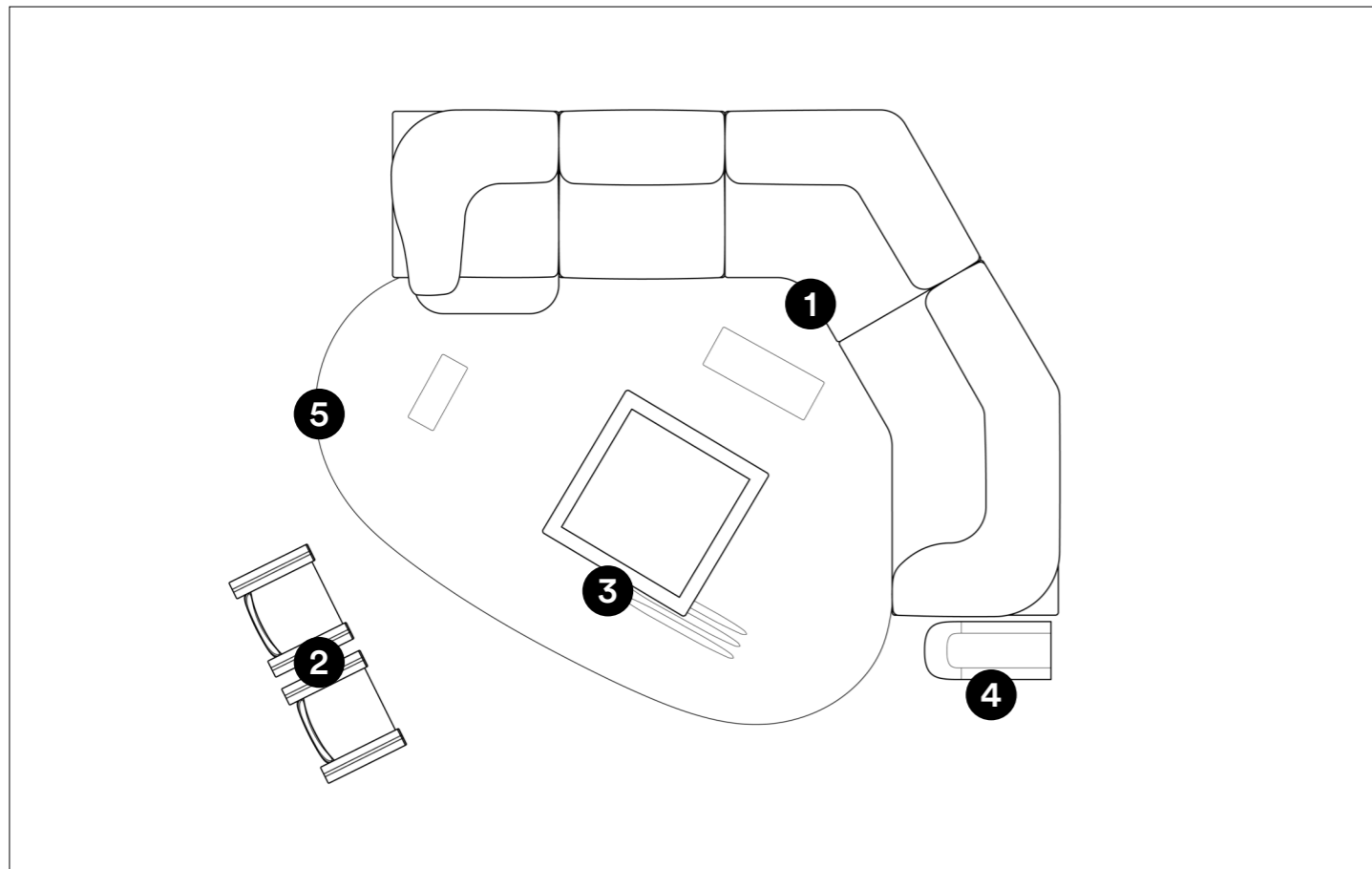

Fabrics & Leathers

Finishes

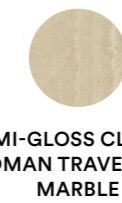
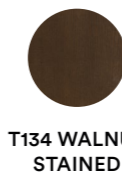



Butter 3-Seater Sofa by Faye Toogood, 2026,  
upholstery Efeu 02.

Butter 3-Seater Sofa by Faye Toogood, 2026,  
upholstery Efeu 02.





Butter Armchair by Faye Toogood, 2026,  
upholstery Efeu 02.







Butter Sofa by Faye Toogood, 2025,  
upholstery Umber 07.





Dana Lamp by Jean-Pierre Garrault & Henri Delord, 2024. Butter Sofa by Faye Toogood, 2025, upholstery Umber 07. Dolmen Side Table by Noé Duchaufour-Lawrance, 2022, top and base T160 Matt Breccia.





Dana Lamp by Jean-Pierre Garrault & Henri Delord, 2024.



Serie 500/4 by Gianfranco Frattini, 2024,  
base T135 Canaletto Walnut. Pi-Dou Vases by  
Alvino Bagni, 2018. Elephant Armchair by Karen  
Chekerdjian, 2021, upholstery Guarana 2006,  
structure T134 Walnut Stained.





Composition BT5

Interior 01

- |   |   |
|---|---|
| <p>1 Butter Sofa Composition BT5<br/><b>Faye Toogood</b><br/>Upholstery Umber 07</p> <p>2 Elephant Armchair<br/><b>Karen Chekerdjian</b><br/>Upholstery Guarana 2006, structure T134 Walnut Stained</p> <p>3 Dolmen Side Table 131 cm<br/><b>Noé Duchaufour-Lawrance</b><br/>Top and base T160 Matt Breccia</p> | <p>4 Serie 500/4<br/><b>Gianfranco Frattini</b><br/>Base T135 Canaletto Walnut</p> <p>5 Dana Lamps<br/><b>Jean-Pierre Garrault &amp; Henri Delord</b></p> <p>6 Pi-Dou Vases<br/><b>Alvino Bagni</b></p> |
|---|---|

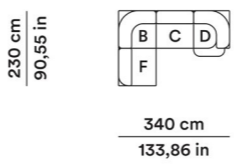
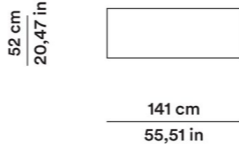
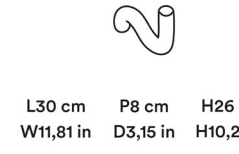
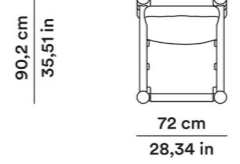
Composition BT5

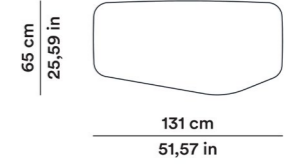
Interior 01

- |   |  |   |
|---|--|---|
| <p>Butter Sofa<br/><b>Composition BT5</b></p>  <p>Serie 500/4<br/><b>0504MD140</b></p>  <p>Pi-Dou Vase 30 cm<br/><b>0AND01</b></p>  | <p>Elephant Armchair<br/><b>OELPPL084</b></p>  <p>Dana Lamp<br/><b>ODNA01</b></p>  | <p>Dolmen Side Table 131 cm<br/><b>ODLMTB131</b></p>  <p>Pi-Dou Vase 25 cm<br/><b>OPDU01</b></p>  |
|---|--|---|

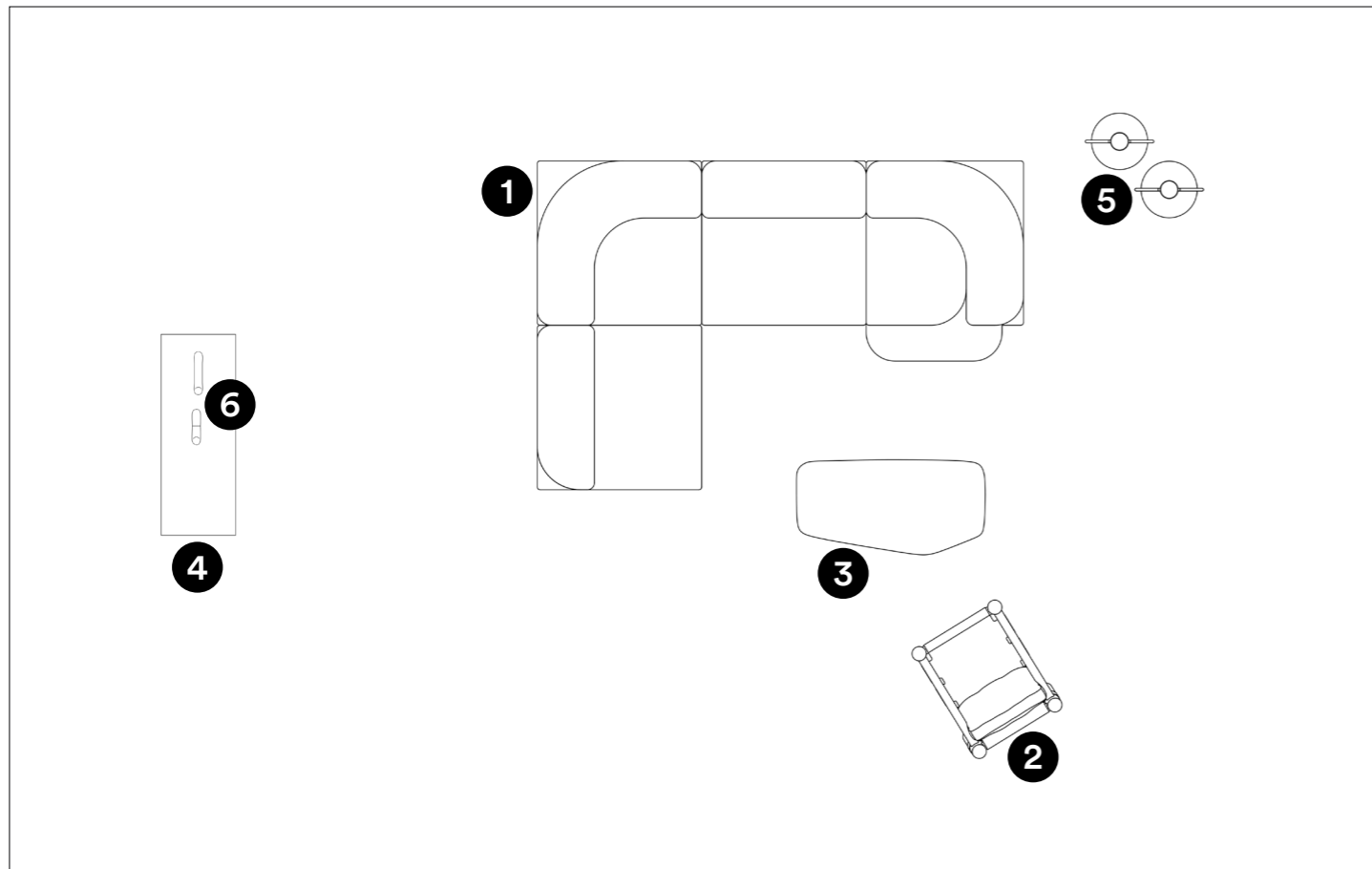

Fabrics & Leathers

Finishes

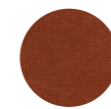

UMBER 07



GUARANA 2006



T134 WALNUT  
STAINED



T160 MATT BRECCIA

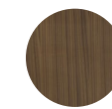

T135 CANALETTO  
WALNUT





Gian Side Table by Studiopepe, 2025, top T212  
Ceppo Appia Antica Marble, base T198 Glossy  
Lacquered White. Butter Sofa by Faye Toogood,  
2025, upholstery Zahir 13.



Isola Bella Daybed by Studiopepe, 2025,  
upholstery Ombra 06, structure T215 Matt  
Chocolate Stained Rattan.



Butter Sofa by Faye Toogood, 2025, upholstery Zahir 13. Mantiqueira Vase by Domingos Tótoro, 2019. Kuschel Rug by Salem van der Swaagh, 2023, color White.

Composition BT7

Interior 01

1 **Butter Sofa Composition BT7**  
**Faye Toogood**  
Upholstery Zahir 13

2 **Isola Bella Daybed**  
**Studiopepe**  
Upholstery Ombra 06, structure T215 Matt  
Chocolate Stained Rattan

3 **Gian Side Table**  
**Studiopepe**  
Top T212 Ceppo Appia Antica Marble, base T198 Glossy  
Lacquered White

4 **Mantiqueira Vases**  
**Domingos Tótora**

5 **Kuschel Rug**  
**Salem van der Swaagh**  
Color White

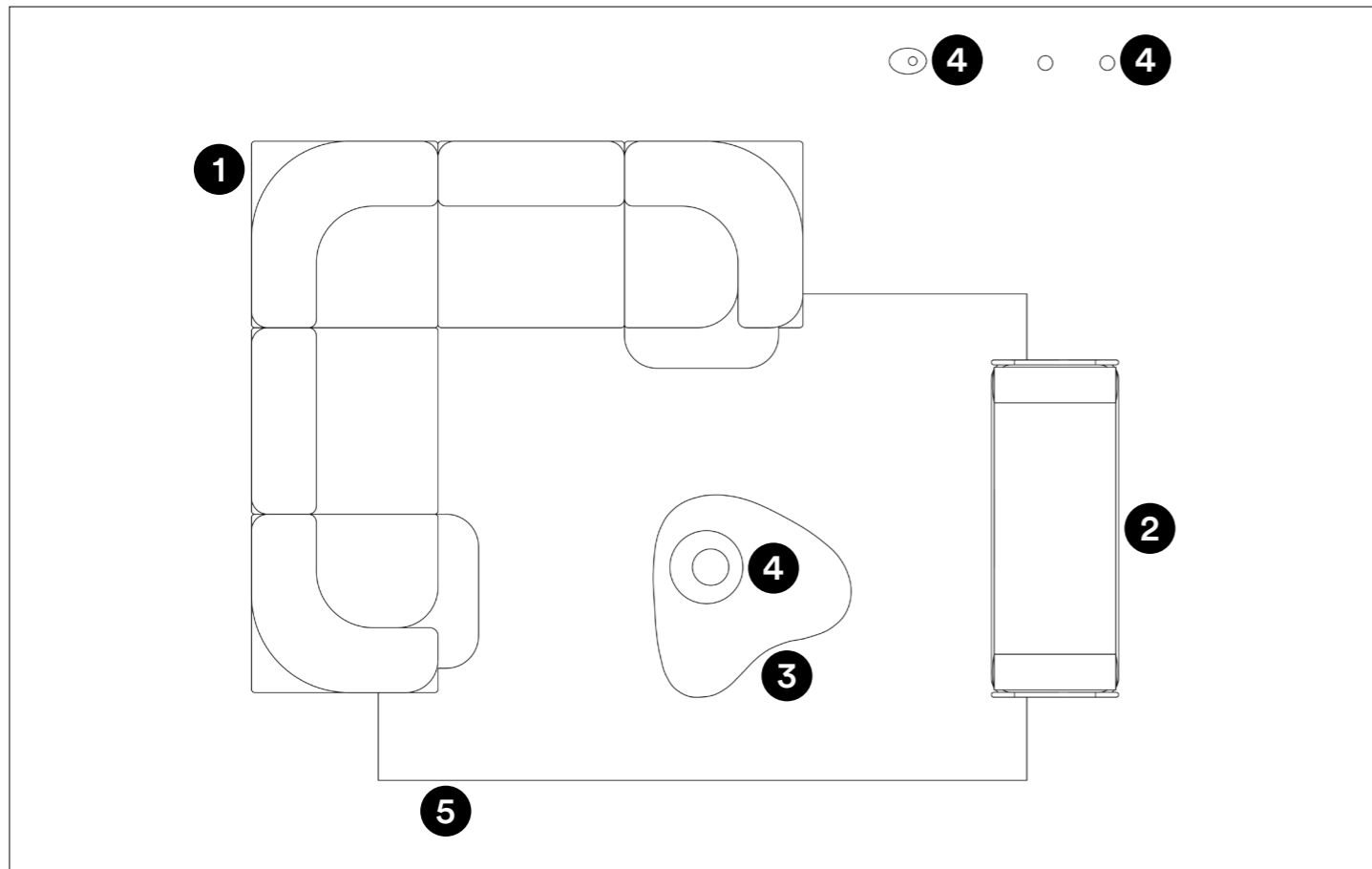

Composition BT7

Interior 01

**Butter Sofa**  
**Composition BT7**

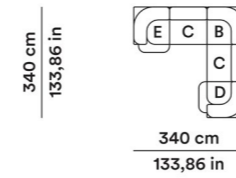

**Mantiqueira Vase**  
**OMNQ01**



L50 cm P50 cm H35 cm  
W19,68 in D19,68 in H13,78 in

**Isola Bella Daybed**  
**OISBDB208**

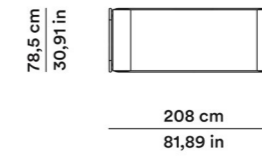

**Mantiqueira Vase**  
**OMNQ02**



L24 cm P16 cm H43 cm  
W9,45 in D6,30 in H16,92 in

**Gian Side Table**  
**OGINTB124**



**Mantiqueira Vase**  
**OMNQ10**



Ø9 cm H49 cm  
Ø3,54 in H19,29 in

**Mantiqueira 02 Vase**  
**OMNQ12**



Ø9 cm H65 cm  
Ø3,54 in H25,59 in

**Kuschel Rug**  
**OKSHTP300X400**

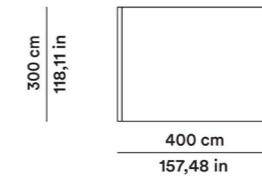

Fabrics & Leathers

Finishes



ZAHIR 13



OMBRA 06



T215 MATT  
CHOCOLATE STAINED  
RATTAN

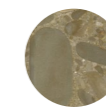

T212 CEPPO APPIA  
ANTICA MARBLE



T198 GLOSSY  
LACQUERED WHITE



KUSCHEL  
WHITE



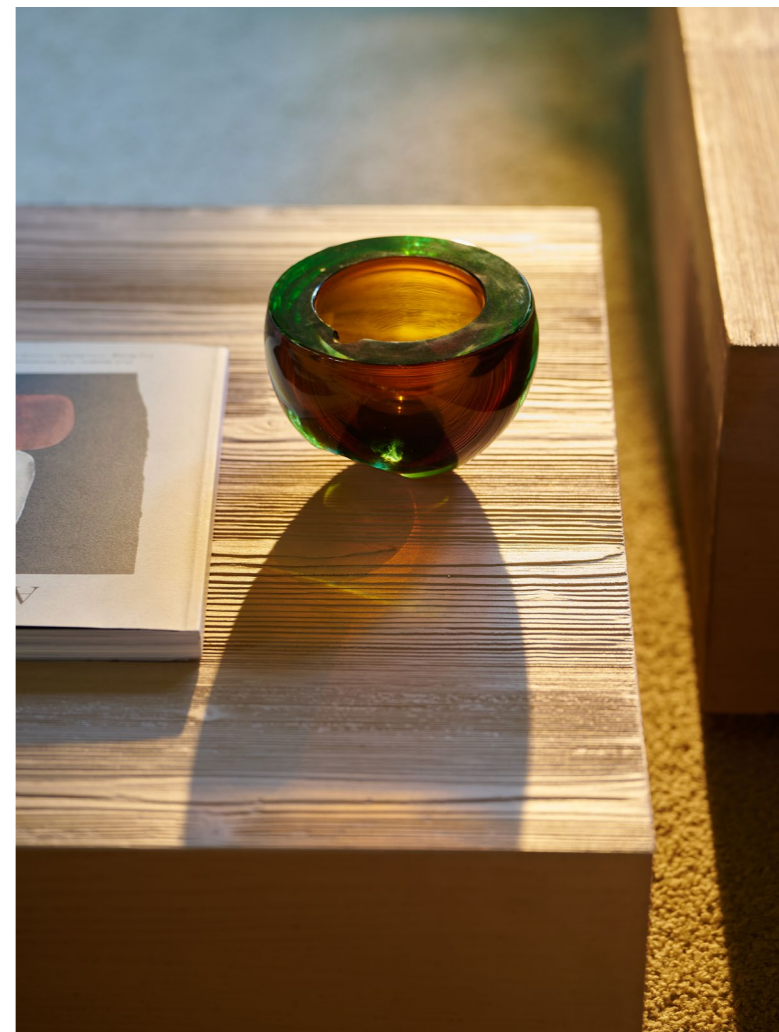

Butter Sofa by Faye Toogood, 2025, upholstery Botan 02. Cassero Side Tables by Roberto Sironi, 2024, structure T194 Earth Tones + T195 Powder Pink. Bread Side Table by Faye Toogood, 2025, structure T134 Walnut Stained, insert Maple Wood. Miss Pack Lamp by Alvino Bagni, 2018, finish T100 Olive Green.



Lina Armchair by Gianfranco Frattini, 2018,  
upholstery Ombra 17, structure T134 Walnut  
Stained. Butter Sofa by Faye Toogood, 2025,  
upholstery Botan 02.



- |   |   |
|---|---|
| <p>1 <b>Butter Sofa Composition BT10</b><br/><b>Faye Toogood</b><br/>Upholstery Botan 02</p> <p>2 <b>Orsola Armchair</b><br/><b>Gastone Rinaldi</b><br/>Upholstery Anilina 02, structure T23 Polished Chrome</p> <p>3 <b>Lina Armchair</b><br/><b>Gianfranco Frattini</b><br/>Upholstery Ombra 17, structure T134 Walnut Stained</p> <p>4 <b>Cassero Side Table</b><br/><b>Roberto Sironi</b><br/>Low Table 110x70 cm T195 Powder Pink</p> <p>5 <b>Cassero Side Table</b><br/><b>Roberto Sironi</b><br/>Low Table 85x85 cm T194 Earth Tones</p> | <p>6 <b>Bread Side Table H40 cm</b><br/><b>Faye Toogood</b><br/>Structure T134 Walnut Stained, insert Maple Wood</p> <p>7 <b>Serie 500/3</b><br/><b>Gianfranco Frattini</b><br/>Base T135 Canaletto Walnut</p> <p>8 <b>A.D.A. Lamp</b><br/><b>Umberto Riva</b><br/>Structure Green Matt</p> <p>9 <b>Miss Pack Lamp</b><br/><b>Alvino Bagni</b><br/>Finish T100 Olive Green</p> <p>10 <b>Kuschel Rug</b><br/><b>Salem van der Swaagh</b><br/>Color White</p> |
|---|---|

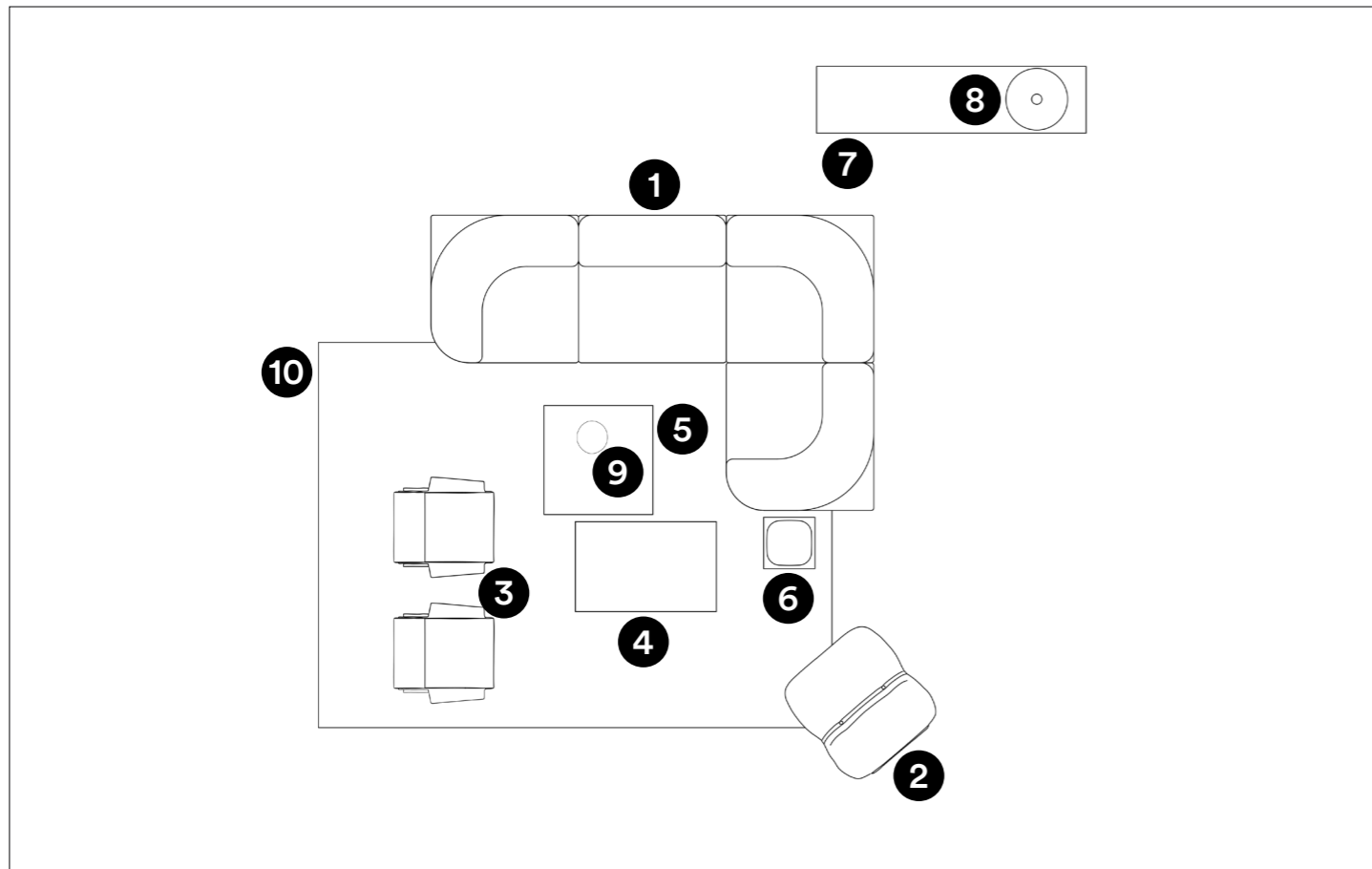

- |   |   |   |
|---|---|---|
| <p><b>Butter Sofa</b><br/><b>Composition BT10</b></p>   | <p><b>Orsola Armchair</b><br/><b>OORSPL090</b></p>      | <p><b>Lina Armchair</b><br/><b>OLNAPL078</b></p>          |
| <p><b>Cassero Side Table</b><br/><b>OCSRTBRT110</b></p> | <p><b>Cassero Side Table</b><br/><b>OCSRTBSQ085</b></p> | <p><b>Bread Side Table H40 cm</b><br/><b>OBRDTB01</b></p> |
| <p><b>Serie 500/3</b><br/><b>0503CR210</b></p>          | <p><b>A.D.A. Lamp</b><br/><b>OADA01</b></p>             | <p><b>Miss Pack Lamp</b><br/><b>OMSP01</b></p>            |

Fabrics & Leathers

Finishes



BOTAN 02



ANILINA 02



T23 POLISHED CHROME



T134 WALNUT STAINED



T195 POWDER PINK



T194 EARTH TONES



OMBRA 17



MAPLE WOOD



T135 CANALETTO WALNUT



GREEN MATT



T100 OLIVE GREEN



KUSCHEL WHITE



- 1 Butter Sofa Composition BT21  
**Faye Toogood**  
Upholstery Efeu 07
- 2 Giulia Armchair  
**Gianfranco Frattini**  
Upholstery Sahara 01, structure T202  
Glossy Lacquered Chocolate
- 3 Brut Side Table  
**Roberto Sironi**  
Top Aluminum, base White Cement
- 4 Torso Side Table  
**Roberto Sironi**  
Structure Polished Chrome Aluminum
- 5 Butter Storage Cabinet  
**Faye Toogood**  
Structure T173 Glossy Lacquered Ivory
- 6 Core Bar Cabinet  
**Tacchini Design Studio**  
Structure T239 Glossy Rosewood
- 7 1809 Floor Lamp  
**Tacchini Design Studio**
- 8 Jacob Rug  
**Salem van der Swaagh**  
White

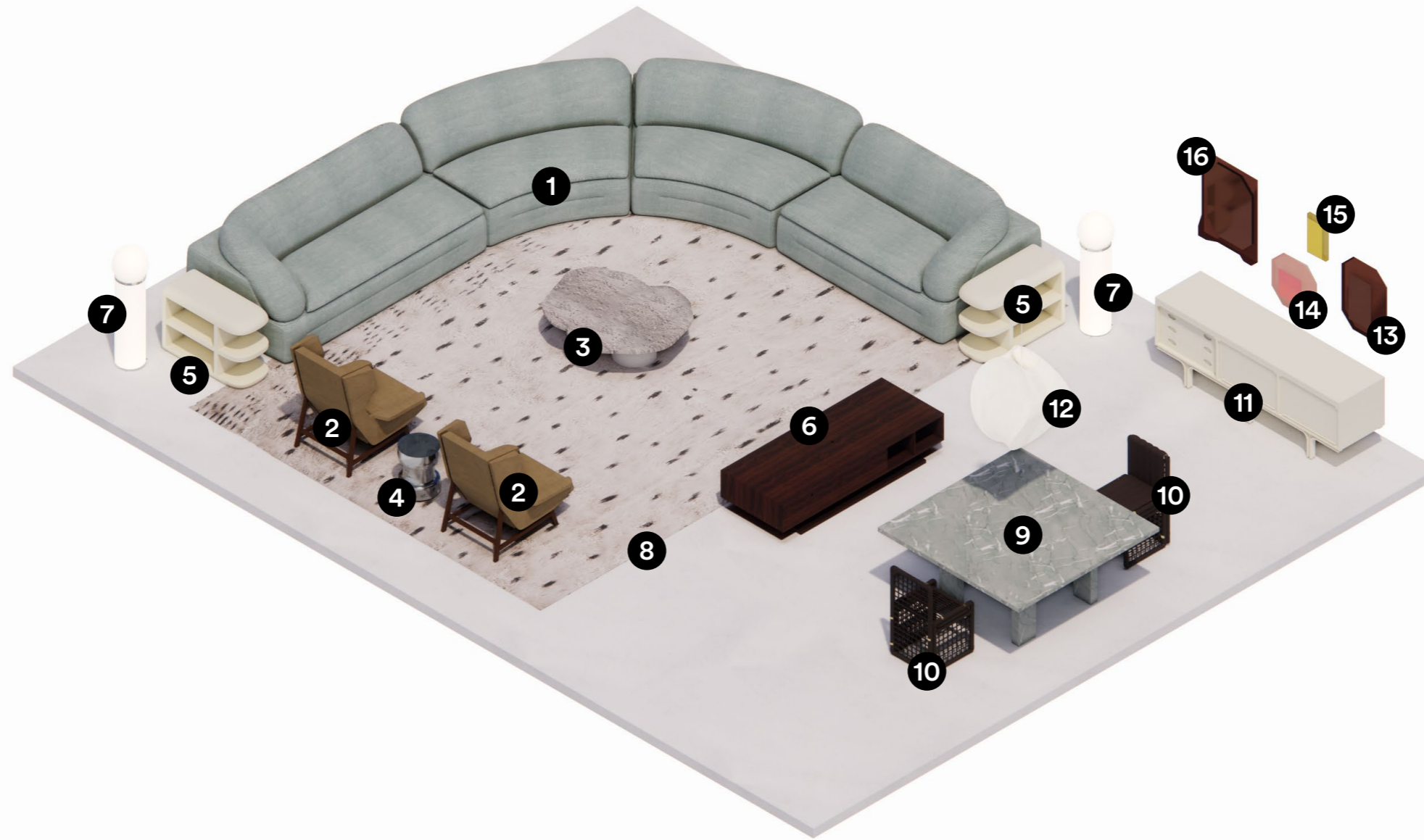

- 9 Clockwise Table  
**Michael Anastassiades**  
Structure T190 Matt Mediterraneo  
Green Marble
- 10 Basilan Chair  
**Tobia Scarpa**  
Upholstery Anilina 06, structure T215  
Matt Chocolate Stained Rattan
- 11 Serie 500/3 Storage Cabinet  
**Gianfranco Frattini**  
Structure T175 Matt Lacquered Ivory
- 12 Equinox Lamp  
**Studiopepe**
- 13 Tact 01 Mirror  
**Objects of Common Interest**  
Brown
- 14 Tact 02 Mirror  
**Objects of Common Interest**  
Pink
- 15 Tact 03 Mirror  
**Objects of Common Interest**  
Yellow
- 16 Trace 01 Mirror  
**Objects of Common Interest**  
Brown

- 1 Butter Sofa Composition BT16  
**Faye Toogood**  
Upholstery Efeu 08
- 2 Orsola Armchair  
**Gastone Rinaldi**  
Upholstery Zahir 15, structure T23  
Polished Chrome
- 3 PietraForma Side Table  
**Roberto Sironi**  
Top T236 Orobico Grey Matt Marble,  
legs T135 Canaletto Walnut
- 4 Butter Storage Cabinet  
**Faye Toogood**  
Structure T223 Glossy Lacquered Beige
- 5 Onigiri Rug  
**Studiopepe**  
Taupe



- 6 Artona Armchair  
**Tobia Scarpa**  
Structure T135 Canaletto Walnut,  
upholstery Velisse 01
- 7 Altar Side Table  
**EWE Studio**  
Finish T183 Brown Ceramic
- 8 Dana Lamp  
**Jean-Pierre Garrault & Henri  
Delord**

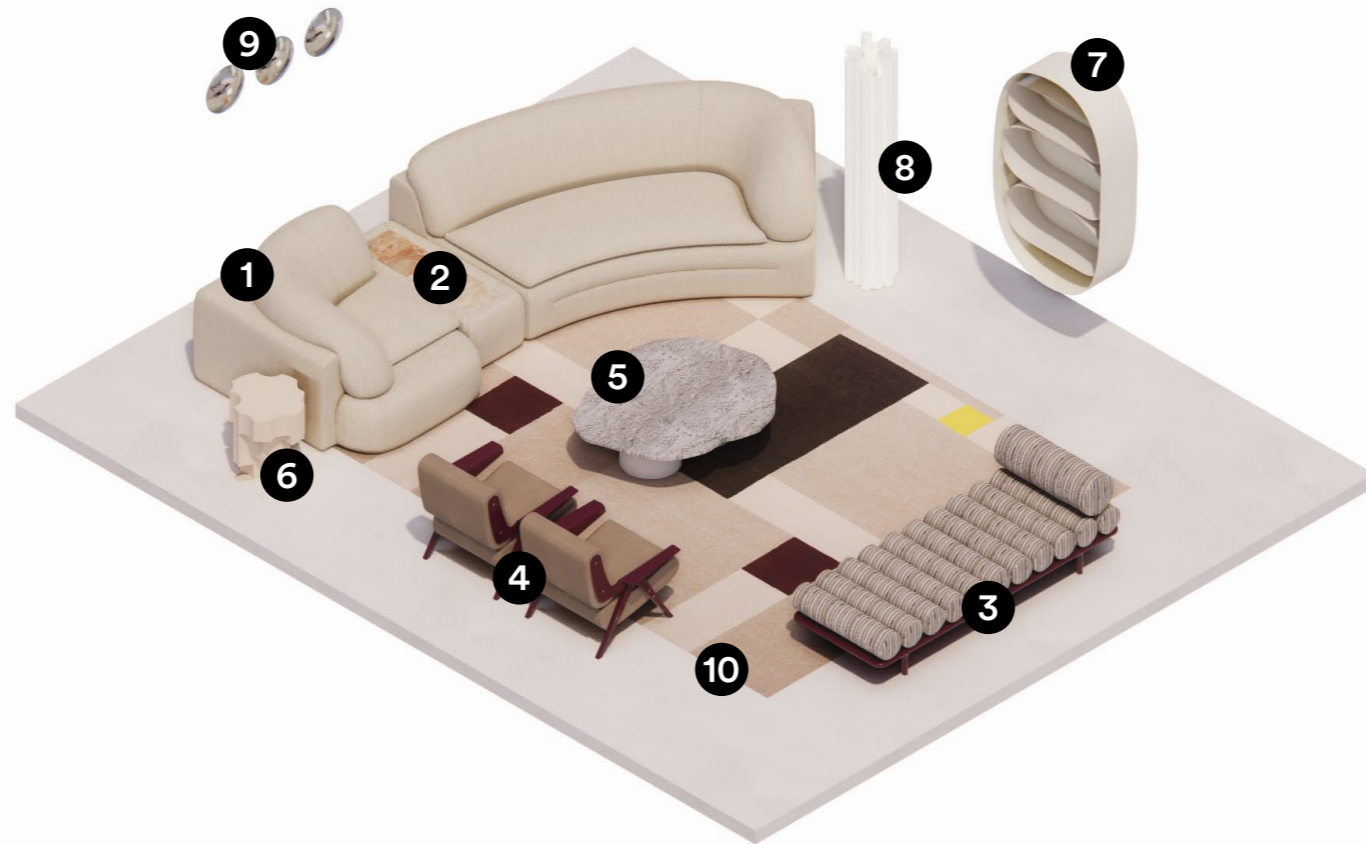

- 1 **Butter Sofa Composition BT12**  
**Faye Toogood**  
Upholstery Dionea 02
- 2 **Butter Low Table**  
**Faye Toogood**  
Upholstery Dionea 02,  
top T160 Matt Breccia Marble
- 3 **Five to Nine Daybed**  
**Studiopepe**  
Upholstery Zolla 01,  
structure T221 Glossy Lacquered Red
- 4 **Lina Armchair**  
**Gianfranco Frattini**  
Upholstery Loom 06,  
structure T221 Glossy Lacquered Red
- 5 **Brut Side Table**  
**Roberto Sironi**  
Top Aluminum, base White Cement

- 6 **Altar Side Table**  
**EWE Studio**  
Finish T208 Cream Ceramic
- 7 **Astral Storage Cabinet**  
**Faye Toogood**  
External structure T173 Glossy Ivory,  
internal structure T197 Matt Ivory
- 8 **Vertical Nest**  
**Brian Thoreen**
- 9 **Andrea Wall Lamp**  
**NUOVA Group**
- 10 **Anni Rug**  
**Studiopepe**  
Yellow

- 1 Butter Sofa Composition BT20  
**Faye Toogood**  
Upholstery Loto 06
- 2 Isola Bella Daybed  
**Studiopepe**  
Upholstery Take 08, structure T215  
Matt Chocolate Stained Rattan
- 3 Sella Armchair  
**Carlo De Carli**  
Upholstery Zareen 07, structure T135  
Canaletto Walnut
- 4 Gian Side Table  
**Studiopepe**  
Top T211 Brushed Sicilian Breccia Marble, base T198 Glossy Lacquered White
- 5 Bread Side Table  
**Faye Toogood**  
Structure T134 Walnut Stained, insert Maple wood
- 6 Mano Light Floor Lamp  
**Umberto Bellardi Ricci**  
Structure T23 Polished Chrome
- 7 Jacob Rug  
**Salem van der Swaagh**  
White



- 8 Torii Love Dining Table  
**Studiopepe**  
Structure T221 Glossy Lacquered Red
- 9 Africa Chair  
**Tobia Scarpa**  
Upholstery Zareen 07, structure T135  
Canaletto Walnut
- 10 Serie 500/3 Storage Cabinet  
**Gianfranco Frattini**  
Structure T135 Canaletto Walnut
- 11 Doric Lamp  
**Umberto Bellardi Ricci**

- 1 Butter Sofa Composition BT7  
**Faye Toogood**  
Upholstery Efeu 02
- 2 Butter Low Table  
**Faye Toogood**  
Upholstery Efeu 02,  
top T161 Brushed Matt Fior di Pesco Marble
- 3 Butter Ottoman  
**Faye Toogood**  
Upholstery Efeu 02
- 4 Vesta Armchair  
**Tacchini Design Studio**  
Upholstery Zurah 07
- 5 Torso Side Table  
**Roberto Sironi**  
Structure Polished Chrome Aluminum

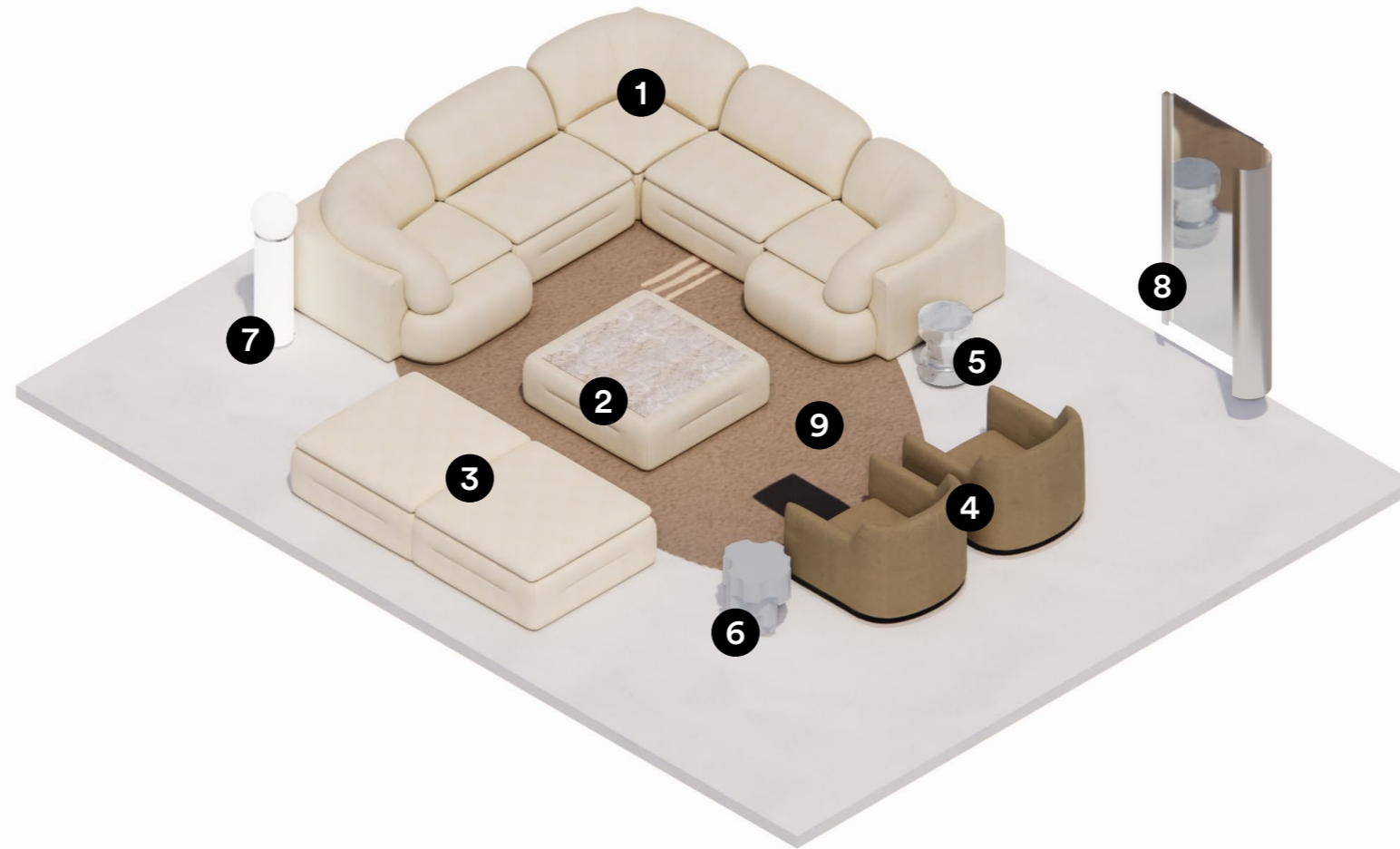

- 6 Altar Side Table  
**EWE Studio**  
Finish T179 Terracotta Cement
- 7 1809 Floor Lamp  
**Tacchini Design Studio**
- 8 Ancora Mirror  
**Umberto Bellardi Ricci**  
Structure T193 Satin Steel
- 9 Onigiri Rug  
**Studiopepe**  
Taupe

1 Butter Sofa Composition BT14  
**Faye Toogood**

Sofa: upholstery Tuna 02  
Low Table: top T161 Brushed  
Matt Fior di Pesco Marble

2 Costela Armchair  
**Martin Eisler**

Upholstery Take 08, structure T134  
Walnut Stained

3 PietraForma Side Table  
**Roberto Sironi**

Top T235 Breccia Sarda Matt Marble,  
base T135 Canaletto Walnut

4 Colonna Side Table  
**Roberto Sironi**

Top 161 Brushed Matt Fior di Pesco  
Marble, base T149 Mirror

5 Torii Love Console  
**Studiopepe**

Structure T201 Glossy Lacquered  
Powder Pink

6 1809 Table Lamp  
**Tacchini Design Studio**

7 Mano Light Table Lamp  
**Umberto Bellardi Ricci**

Structure T23 Polished Chrome

8 Tact 01 Mirror  
**Objects of Common Interest**

Brown

9 Tact 02 Mirror  
**Objects of Common Interest**

Pink

10 Tact 03 Mirror  
**Objects of Common Interest**

Light Blue

11 Onigiri Rug  
**Studiopepe**

Grey

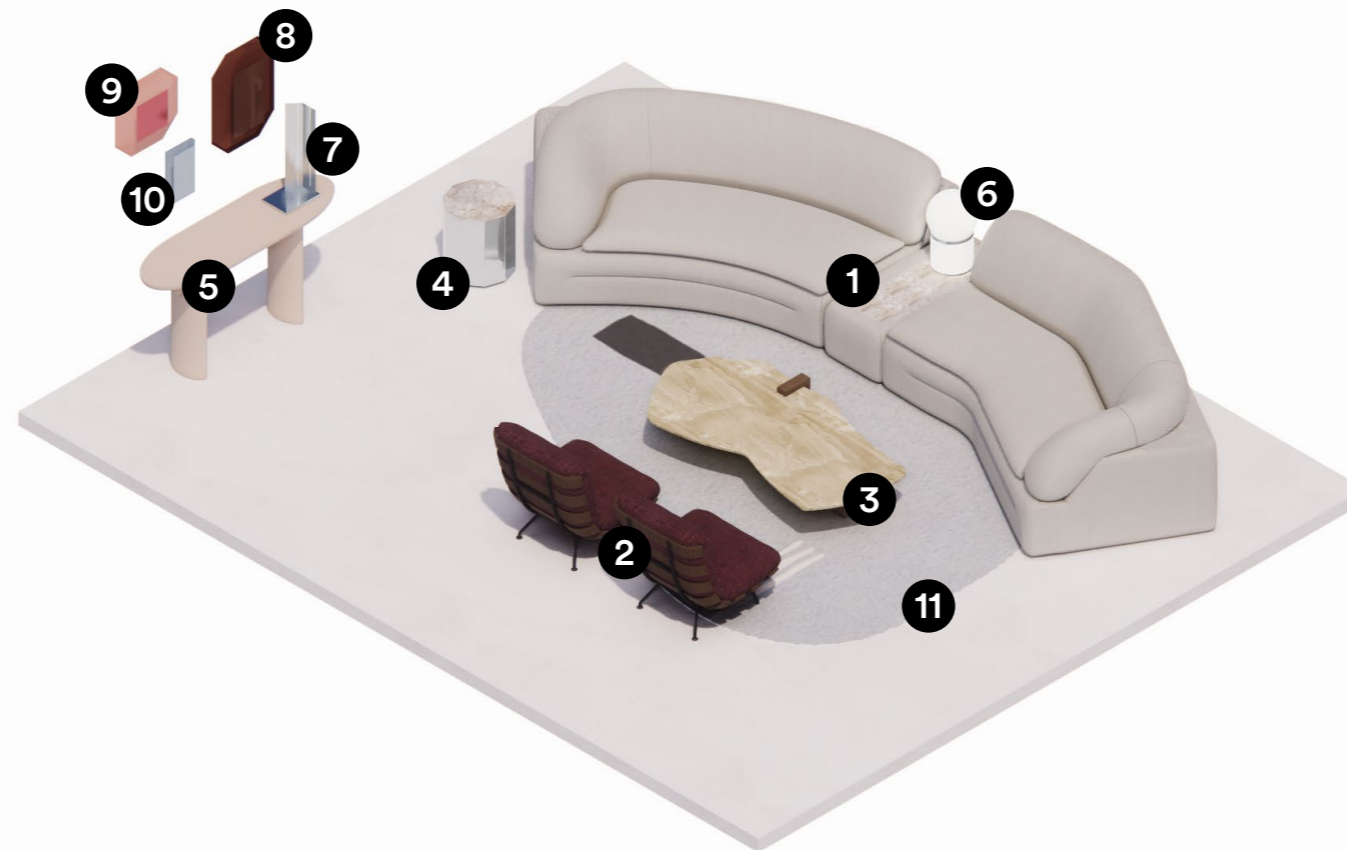



## Technical Data

Butter is a sculptural, squashy, modular sofa. Generous, butter-soft upholstery melts across oversized building block structures that can be curated and rearranged to your taste.

### **Interior structure**

Wooden frame

### **Padding**

Multi-density Polyurethane Foam

### **Seat cushion**

Hypoallergenic fiber

### **Upholstery**

Fabric or Leather  
Removable covers

Suggested Compositions

Butter  
Composition BT5

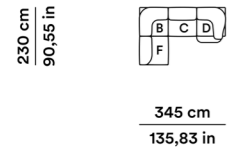

Butter  
Composition BT7

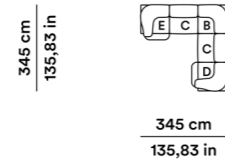

Butter  
Composition BT10

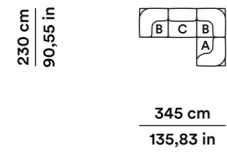

Butter  
Composition BT11

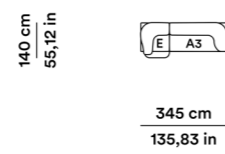

Butter  
Composition BT12

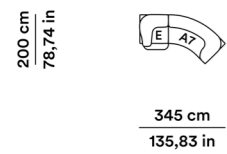

Butter  
Composition BT13

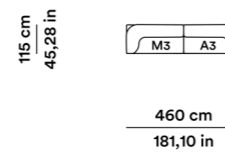

Butter  
Composition BT14

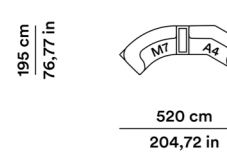

Butter  
Composition BT15

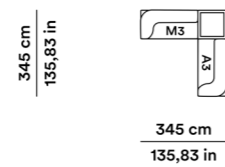

Suggested Compositions

Butter  
Composition BT16

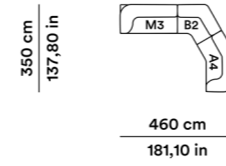

Butter  
Composition BT17

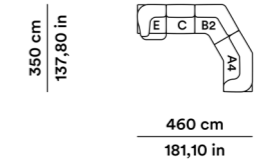

Butter  
Composition BT18

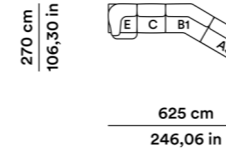

Butter  
Composition BT19

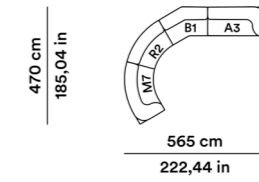

Butter  
Composition BT20

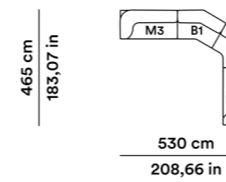

Butter  
Composition BT21

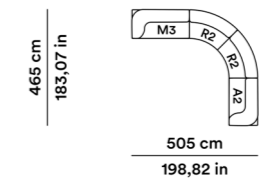

**Butter Sofa Modules**

Module M  
**OBTTTA110SX**

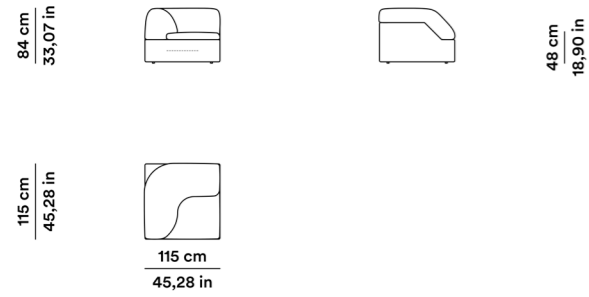

Module M1  
**OBTTE150SX**

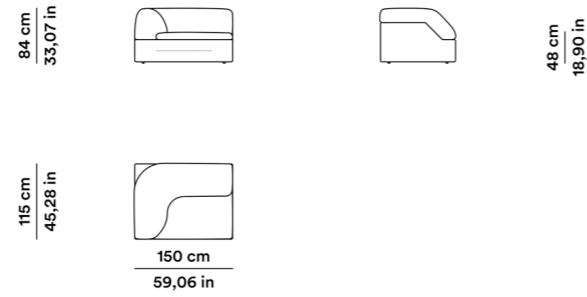

**Butter Sofa Modules**

Module M6  
**OBTTECT01SX**

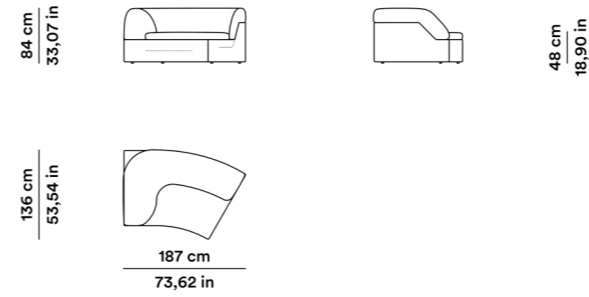

Module M7  
**OBTTECT02SX**

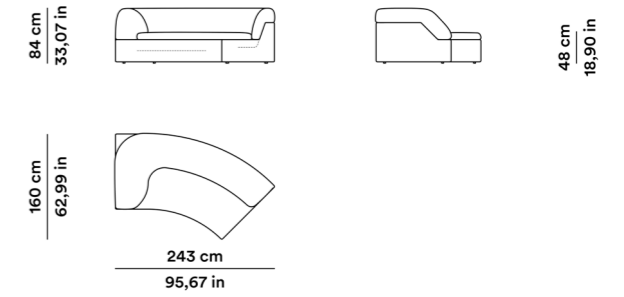

Module M2  
**OBTTE190SX**

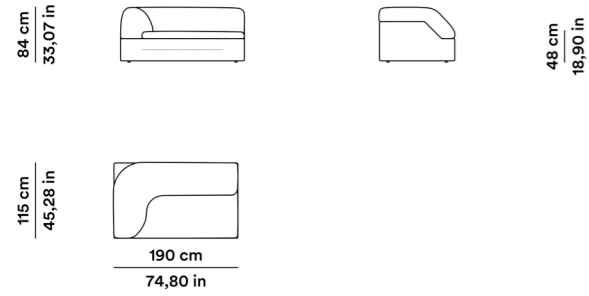

Module M3  
**OBTTE230SX**

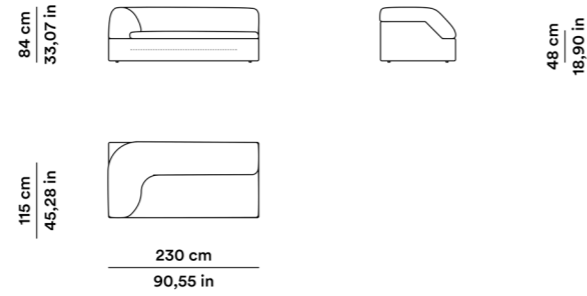

Module E  
**OBTTDPTA110SX**

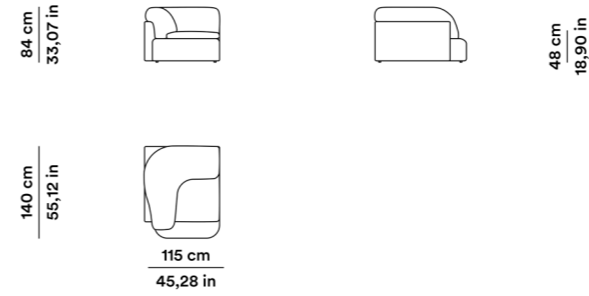

Module F  
**OBTTET110SX**

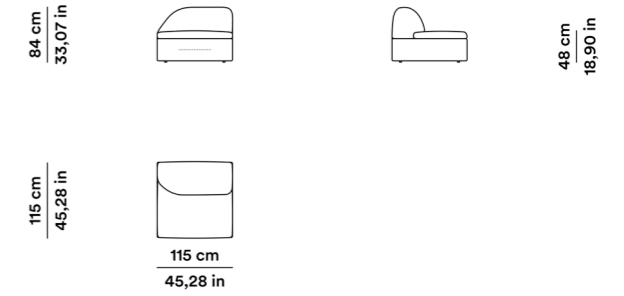

Module M4  
**OBTAT01SX**

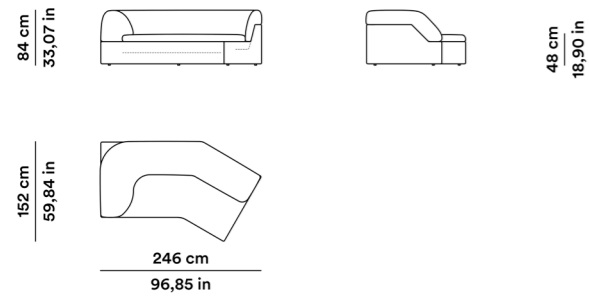

Module M5  
**OBTAT02SX**

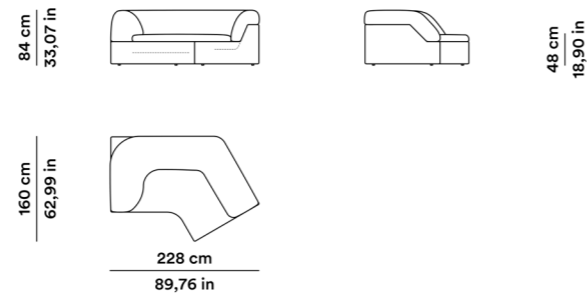

Module A  
**OBTTA110DX**

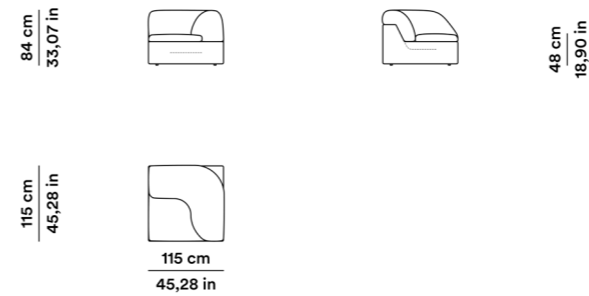

Module A1  
**OBTTE150DX**

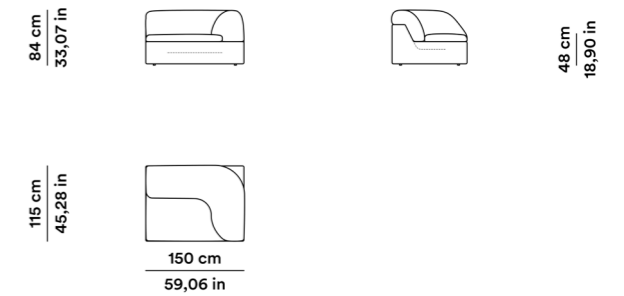

**Butter Sofa Modules**

Module A2  
**OBTTE190DX**

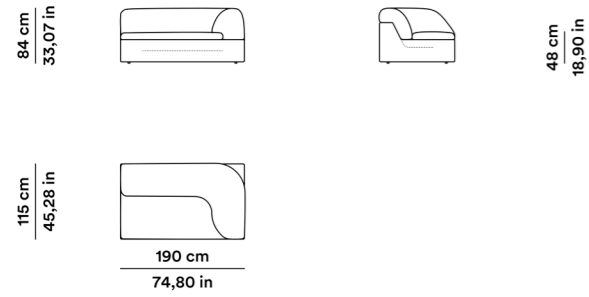

Module A3  
**OBTTE230DX**

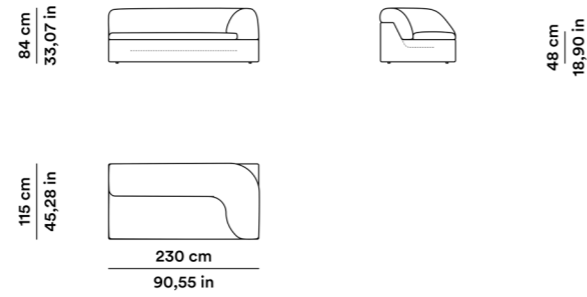

Module A4  
**OBTAT01DX**

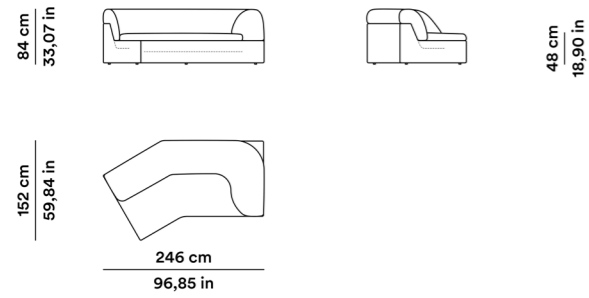

Module A5  
**OBTAT02DX**

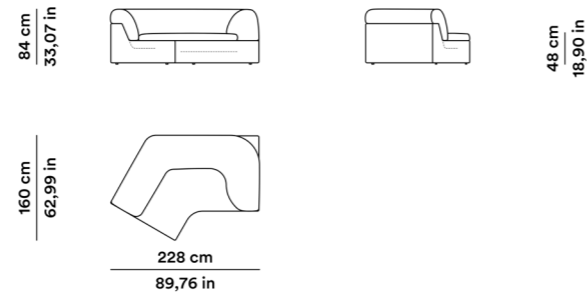

Module A6  
**OBTTECT01DX**

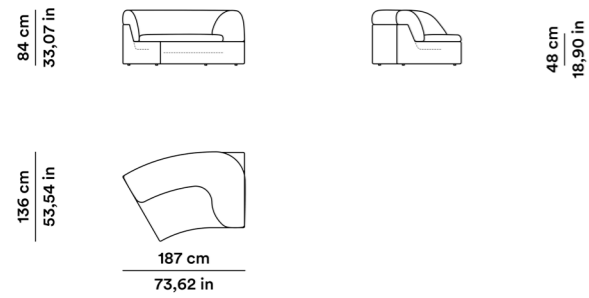

Module A7  
**OBTTECT02DX**

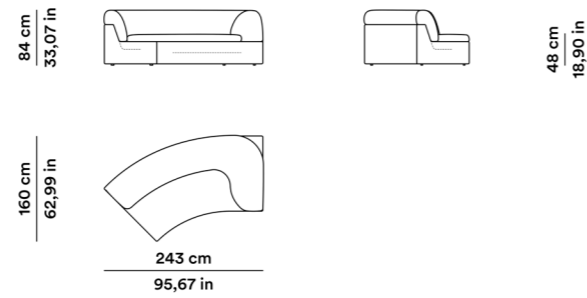

**Butter Sofa Modules**

Module D  
**OBTTDPTA110DX**

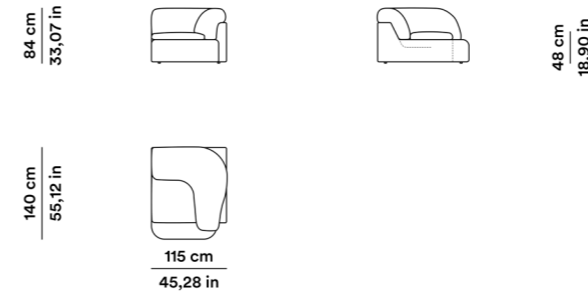

Module H  
**OBTTET110DX**

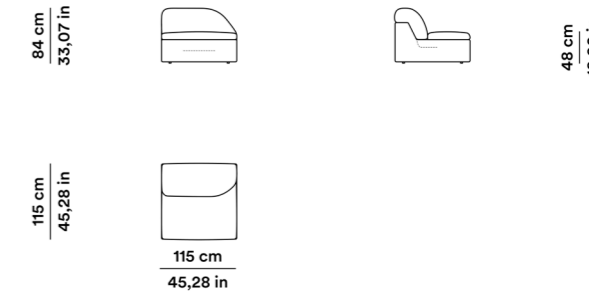

Module C  
**OBTTEL110**

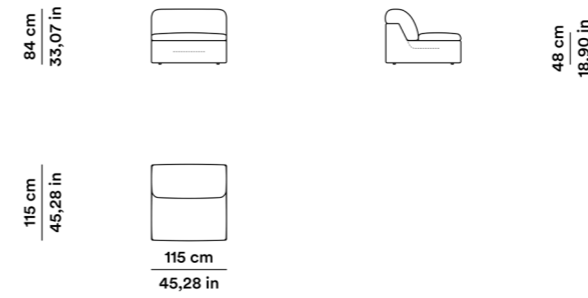

Module C1  
**OBTTEL140**

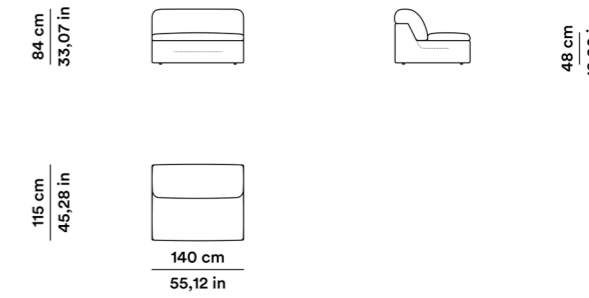

Module C2  
**OBTTEL210**

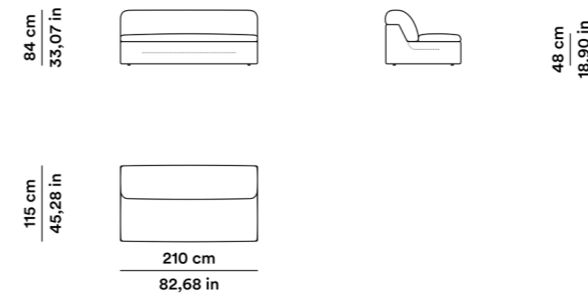

Module B  
**OBTTEA110**

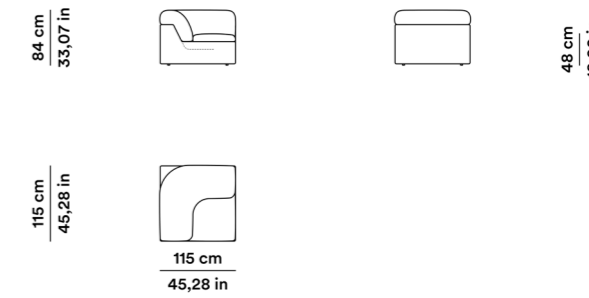

**Butter Sofa Modules**

Module B1  
OBTTEA01

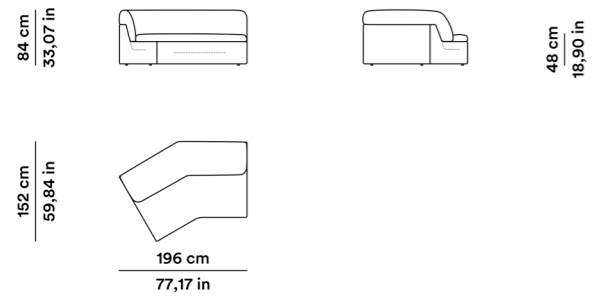

Module B2  
OBTTEA02

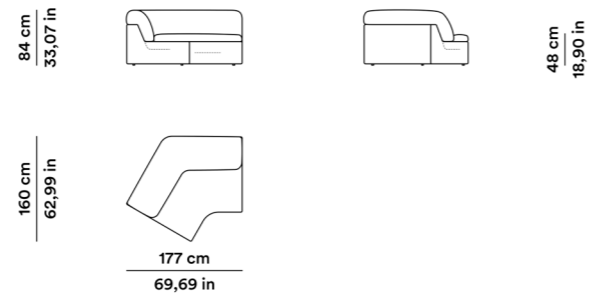

Module R1  
OBTTECC01

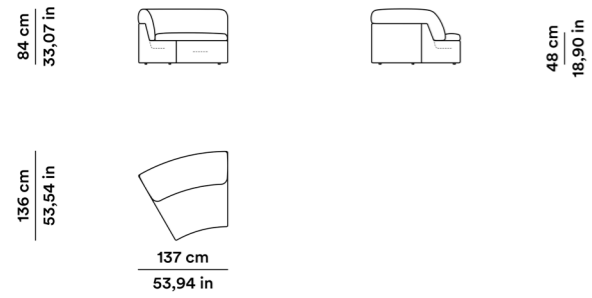

Module R2  
OBTTECC02

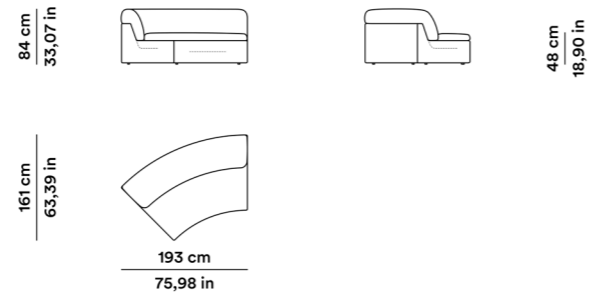

Module S1 / Three-seater Sofa  
OBTAT01SX

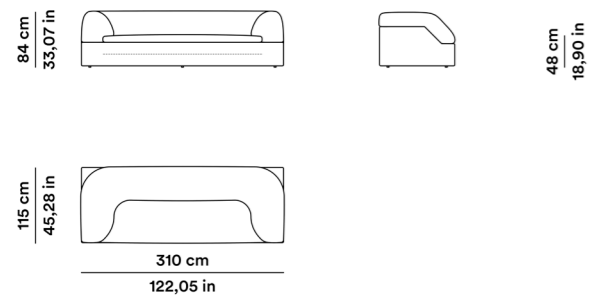

**Butter Collection Modules**

Module P1 / Pouf  
OBTTPF01

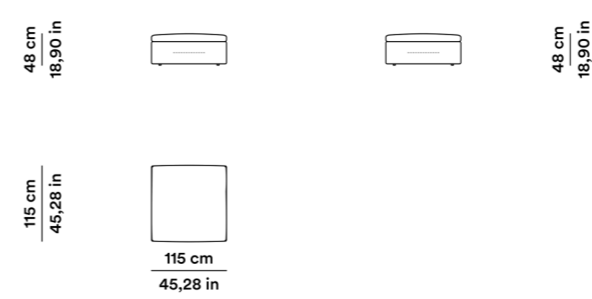

Module P3 / Pouf  
OBTTPF02

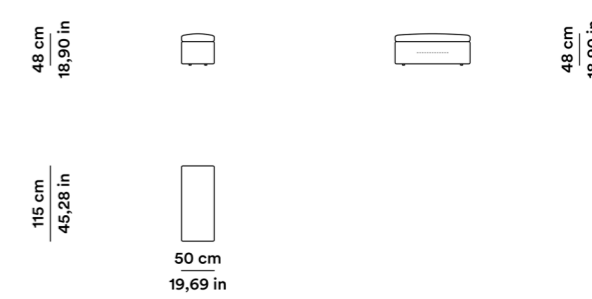

Module P2 / Coffee table  
OBTTTB01



Module P4 / Coffee table  
OBTTTB02

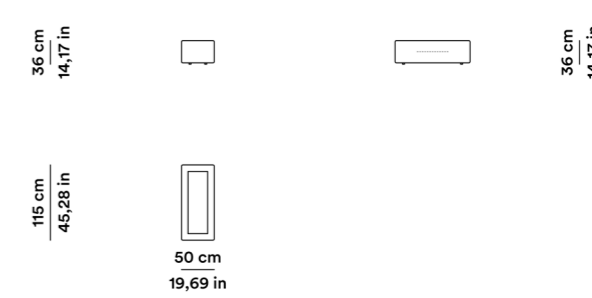

Module L1 / Armchair  
OBTPL110

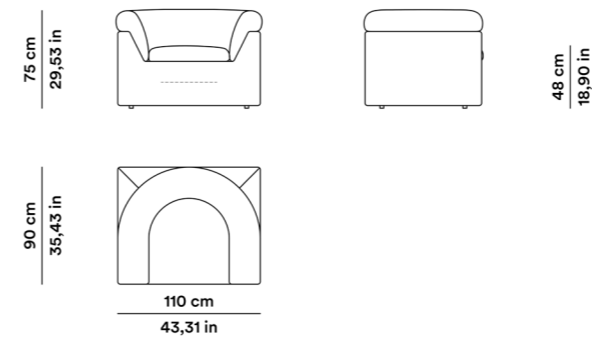

Storage Cabinet  
OBTTLB01LL

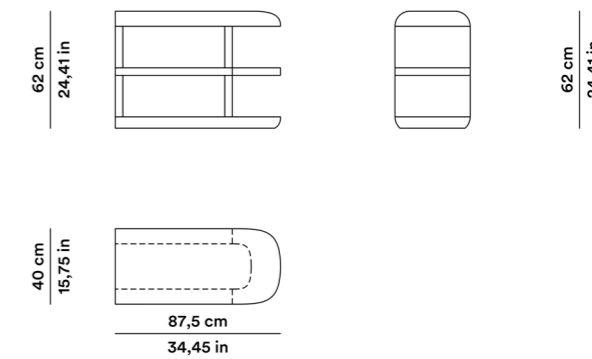

Tacchini Italia Forniture Srl  
Via Domodossola, 19  
20822 Seveso (MB), Italy  
+39 0362 50 41 82  
hello@tacchini.it  
www.tacchini.it

**Creative Direction**  
Giusi Tacchini

**Photography**  
De Pasquale+Maffini  
Andrea Ferrari  
Valentina Sommariva  
Cartography

**Graphic Design**  
Tacchini Italia Forniture Srl

© Tacchini Italia Forniture Srl  
All rights reserved. No part of this publication may be reproduced or transmitted in any form or by any means, electronic or mechanical, without prior permission of the owner. All copyrights and intellectual property rights, including trademarks, patents and copyrights, remain the property of Tacchini Italia Forniture Srl and are explicitly reserved.





**Tacchini**